

8 Karnaugh maps = (truth table + Venn diagram)

8.1 Two input K-maps

	A	0	1
B	0	m_0	m_2
	1	m_1	m_3

XOR gate

x_1	x_2	f
0	0	0
0	1	1
1	0	1
1	1	0

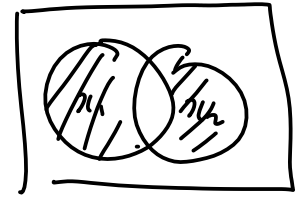

8.2 Three input K-maps

$0 \quad 1 \quad 3 \rightarrow 2$

	AB	00	01	11	10
C	0	m_0	m_2	m_6	m_4
	1	m_1	m_3	m_7	m_5

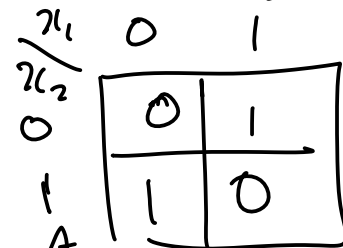
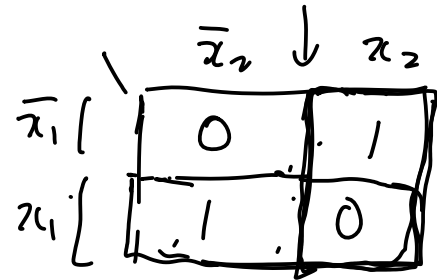

8.3 Four input K-maps

	AB	00	01	11	10
CD	00	m_0	m_4	m_{12}	m_8
	01	m_1	m_5	m_{13}	m_9
	11	m_3	m_7	m_{15}	m_{11}
	10	m_2	m_6	m_{14}	m_{10}

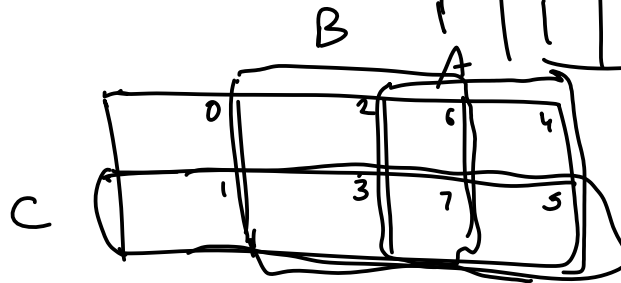

8.4 Five input K-maps





A = 0

	BC	00	01	11	10
DE	00	m_0	m_4	m_{12}	m_8
	01	m_1	m_5	m_{13}	m_9
	11	m_3	m_7	m_{15}	m_{11}
	10	m_2	m_6	m_{14}	m_{10}

A = 1

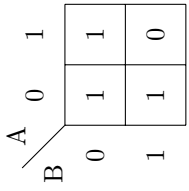
	BC	00	01	11	10
DE	00	m_{16}	m_{20}	m_{28}	m_{24}
	01	m_{17}	m_{21}	m_{29}	m_{25}
	11	m_{19}	m_{23}	m_{31}	m_{27}
	10	m_{18}	m_{22}	m_{30}	m_{26}

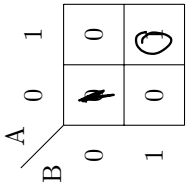
9 More Gates and notations summary

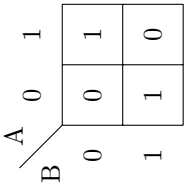
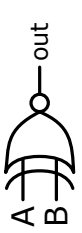
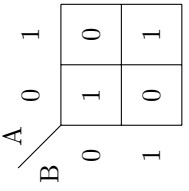
Name	C/Verilog	Boolean expr.	Truth Table	(ANSI) symbol	K-map															
NAND Gate	$Q = \sim(x1 \& x2)$	$Q = \overline{x_1 \cdot x_2} = \overline{x_1}x_2$	<table border="1"> <thead> <tr> <th>x_1</th> <th>x_2</th> <th>$\overline{x_1 \cdot x_2}$</th> </tr> </thead> <tbody> <tr> <td>0</td> <td>0</td> <td>1</td> </tr> <tr> <td>0</td> <td>1</td> <td>1</td> </tr> <tr> <td>1</td> <td>0</td> <td>1</td> </tr> <tr> <td>1</td> <td>1</td> <td>0</td> </tr> </tbody> </table>	x_1	x_2	$\overline{x_1 \cdot x_2}$	0	0	1	0	1	1	1	0	1	1	1	0		
x_1	x_2	$\overline{x_1 \cdot x_2}$																		
0	0	1																		
0	1	1																		
1	0	1																		
1	1	0																		
NOR Gate	$Q = \sim(x1 x2)$	$Q = \overline{x_1 + x_2}$	<table border="1"> <thead> <tr> <th>x_1</th> <th>x_2</th> <th>$\overline{x_1 + x_2}$</th> </tr> </thead> <tbody> <tr> <td>0</td> <td>0</td> <td>1</td> </tr> <tr> <td>0</td> <td>1</td> <td>0</td> </tr> <tr> <td>1</td> <td>0</td> <td>0</td> </tr> <tr> <td>1</td> <td>1</td> <td>0</td> </tr> </tbody> </table>	x_1	x_2	$\overline{x_1 + x_2}$	0	0	1	0	1	0	1	0	0	1	1	0		
x_1	x_2	$\overline{x_1 + x_2}$																		
0	0	1																		
0	1	0																		
1	0	0																		
1	1	0																		
XOR Gate	$Q = x1 \wedge x2$	$Q = x_1 \oplus x_2$	<table border="1"> <thead> <tr> <th>x_1</th> <th>x_2</th> <th>$x_1 \oplus x_2$</th> </tr> </thead> <tbody> <tr> <td>0</td> <td>0</td> <td>0</td> </tr> <tr> <td>0</td> <td>1</td> <td>1</td> </tr> <tr> <td>1</td> <td>0</td> <td>1</td> </tr> <tr> <td>1</td> <td>1</td> <td>0</td> </tr> </tbody> </table>	x_1	x_2	$x_1 \oplus x_2$	0	0	0	0	1	1	1	0	1	1	1	0		
x_1	x_2	$x_1 \oplus x_2$																		
0	0	0																		
0	1	1																		
1	0	1																		
1	1	0																		
XNOR Gate	$Q = \sim(x1 \wedge x2)$	$Q = \overline{x_1 \oplus x_2}$	<table border="1"> <thead> <tr> <th>x_1</th> <th>x_2</th> <th>$\overline{x_1 \oplus x_2}$</th> </tr> </thead> <tbody> <tr> <td>0</td> <td>0</td> <td>1</td> </tr> <tr> <td>0</td> <td>1</td> <td>0</td> </tr> <tr> <td>1</td> <td>0</td> <td>0</td> </tr> <tr> <td>1</td> <td>1</td> <td>1</td> </tr> </tbody> </table>	x_1	x_2	$\overline{x_1 \oplus x_2}$	0	0	1	0	1	0	1	0	0	1	1	1		
x_1	x_2	$\overline{x_1 \oplus x_2}$																		
0	0	1																		
0	1	0																		
1	0	0																		
1	1	1																		

NAND gate

A	B	f
0	0	1
0	1	1
1	0	1
1	1	0

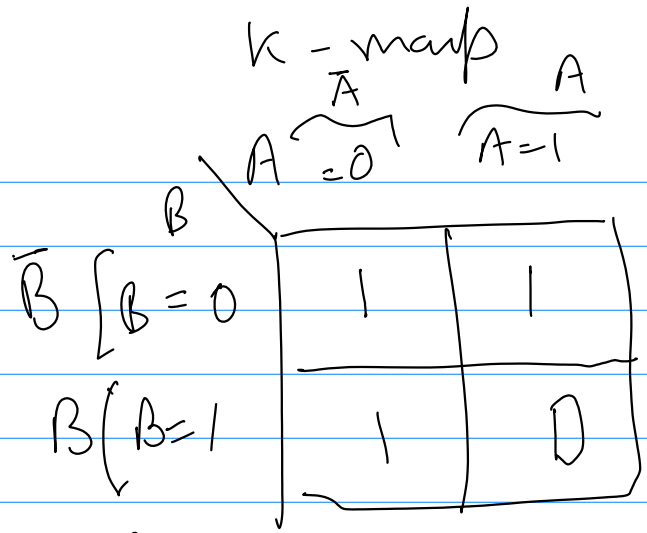

NOR gate
OR \rightarrow NOT

$$f = A + B$$

K-map

A	B	g	f
0	0	0	1
0	1	1	0
1	0	1	0
1	1	1	0

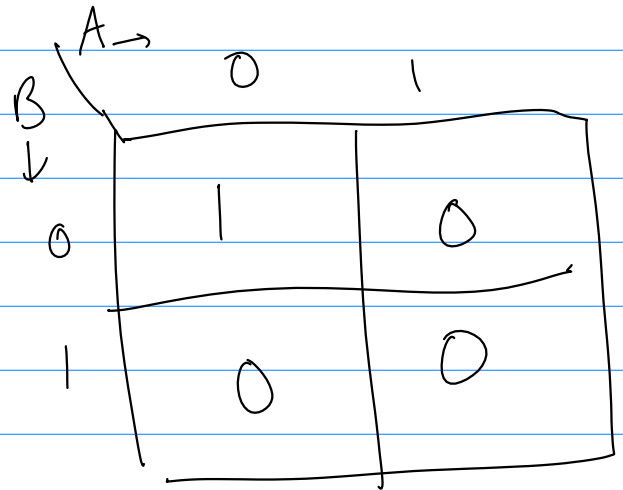

$\overrightarrow{A, B, C, D}$

Example 10. Convert the following Boolean expression into a K-map. $f = \overline{AB} + CD$

$f = m_1 + m_5 + m_{13}$

$f =$

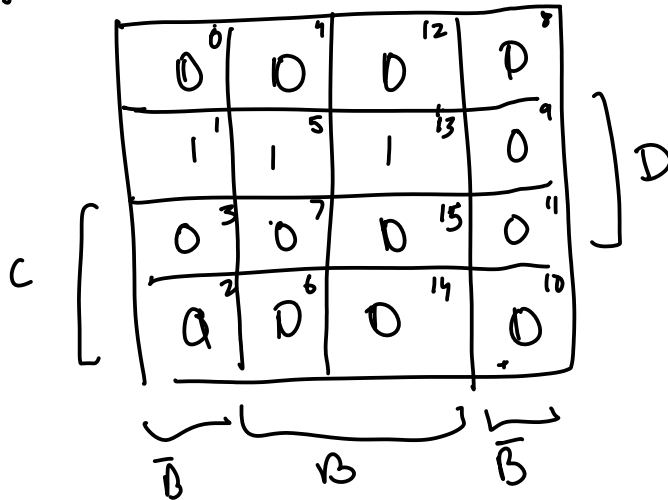

$g_1 = A\bar{B}$

$g_2 = g_1 + C$

$g_3 = \overline{g_2}$

$f = g_3 \cdot D$

Problem 10. Convert the following logic circuit into a K-map.

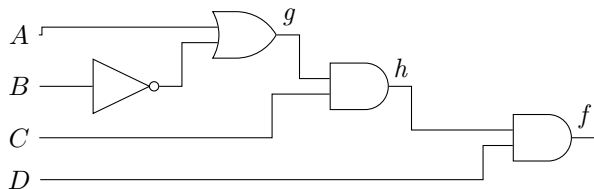

10 Boolean Algebra

10.1 Axioms of Boolean algebra

1. $0 \cdot 0 = 0$

$0 \cdot 0 = 0$

2. $1 + 1 = 1$

$0 \cdot 1 = 0$

$1 \cdot 0 = 0$

13

$1 \cdot 1 = 1$

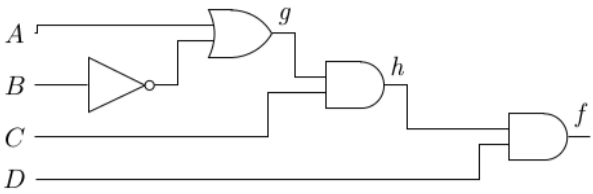

A B C D
AB →

	A			
CD	00	01	11	10
00	0	0	0	0
01	0	0	0	0
11	1	0	1	1
10	1	0	1	1

$g = A + \bar{B}$

	A			
AB	00	01	11	10
CD	00	01	11	10
00	1	0	1	1
01	1	0	1	1
11	1	0	1	1
10	1	0	1	1

$h = g \cdot C$

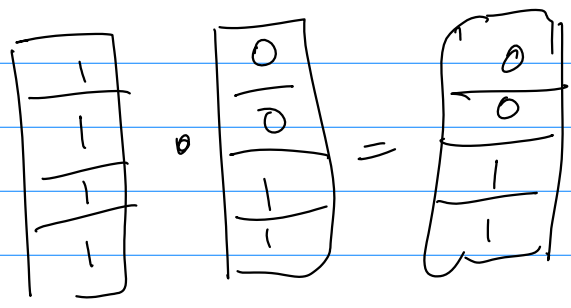

$A =$

	A			
AB	00	01	11	10
C	0	0	1	1
0	0	0	1	1
0	0	1	1	1
0	0	1	1	1

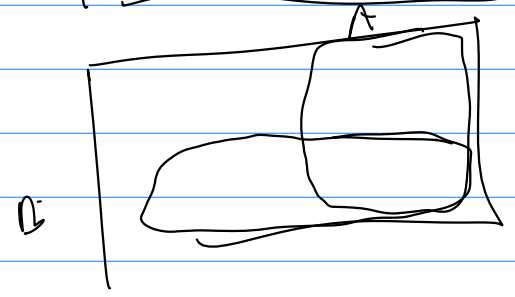
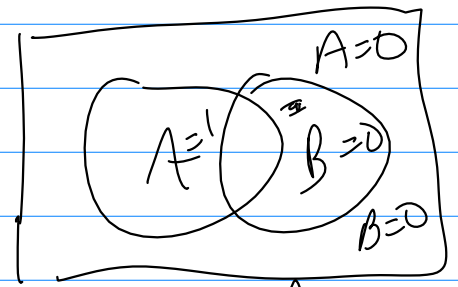

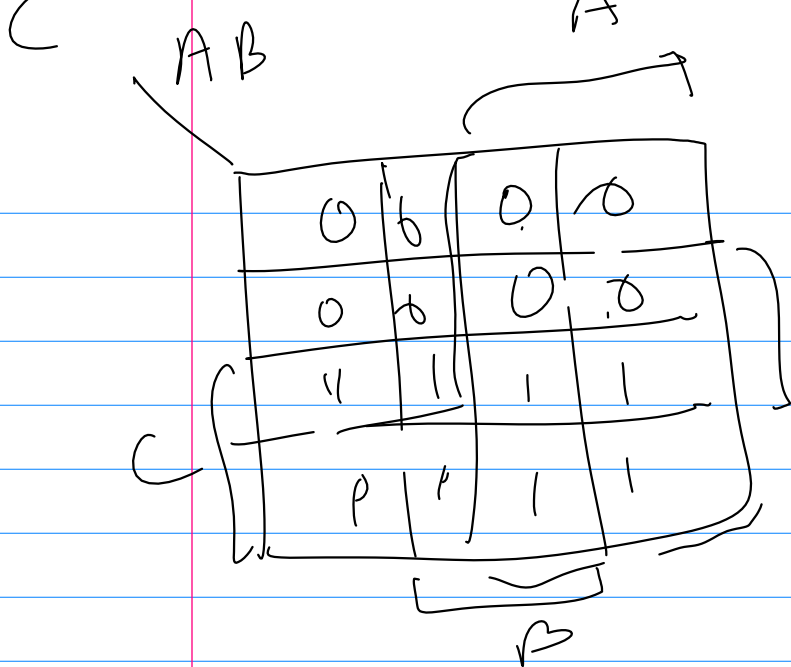

$f =$

$$f = h \cdot D$$

$$= (A + \bar{B}) C \cdot D$$

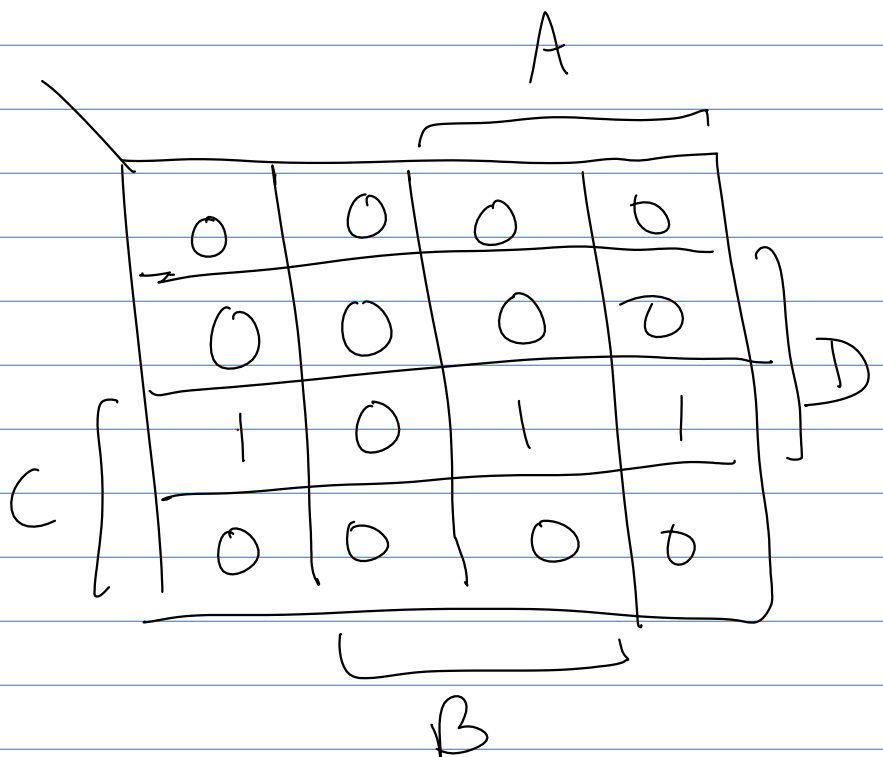

Duality exists in axioms

3. $1 \cdot 1 = 1$
4. $0 + 0 = 0$
5. $0 \cdot 1 = 1 \cdot 0 = 0$
6. $\overline{\overline{0}} = 1$
7. $\overline{\overline{1}} = 0$
8. $x = 0$ if $x \neq 1$
9. $x = 1$ if $x \neq 0$

$$\overline{0} = 1$$

$$\overline{1} = 0$$

10.2 Single variable theorems (Prove by drawing K-maps)

1. $x \cdot 0 = 0$

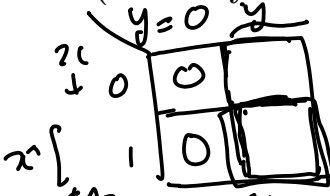

2. $x + 1 = 1$

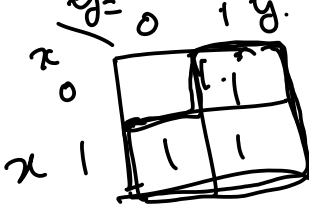

3. $x \cdot 1 = x$

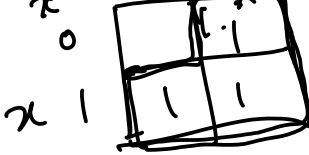

4. $x + 0 = x$

5. $x \cdot x = x$

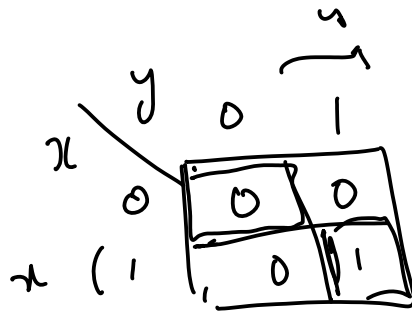

$$x = 0$$

6. $x + x = x$

7. $x \cdot \bar{x} = 0$

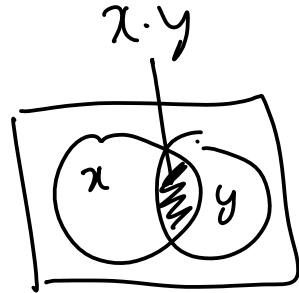

$$x \cdot y$$

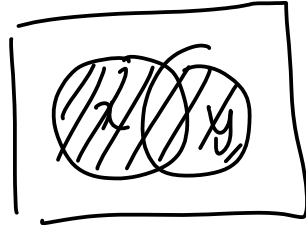

Duality
 $\cdot \rightarrow +$
 $0 \rightarrow 1$
 $+ \rightarrow \cdot$
 $1 \rightarrow 0$

Th 2 is the dual of Th. 1

$$8. x + \bar{x} = 1$$

$$9. \bar{\bar{x}} = x$$

Remark 2 (Duality). Swap + with \cdot and 0 with 1 to get another theorem

10.3 Two and three variable properties (Prove by K-maps)

$$1. \text{Commutative: } x \cdot y = y \cdot x, x + y = y + x$$

$$2. \text{Associative: } x \cdot (y \cdot z) = (x \cdot y) \cdot z, x + (y + z) = (x + y) + z$$

$$x \cdot y \cdot z$$

Duals

$$3. \text{Distributive: } x \cdot (y + z) = x \cdot y + x \cdot z, x + y \cdot z = (x + y) \cdot (y + z)$$

$$x + y \cdot z = (x + y) \cdot (x + z)$$

$$\text{RHS} = (x + y) \cdot (y + z) = x \cdot (y + z) + y \cdot (y + z)$$

$$= x \cdot y + x \cdot z + y \cdot y + y \cdot z$$

$$= x \cdot y + x \cdot z + y + y \cdot z = y \cdot (x + 1 + z) + x \cdot z$$

$$4. \text{Absorption: } x + x \cdot y = x, x \cdot (x + y) = x$$

$$= y \cdot (1 + z) + x \cdot z$$

$$= y \cdot 1 + x \cdot z = y + x \cdot z$$

$$LHS = x + y \cdot z$$

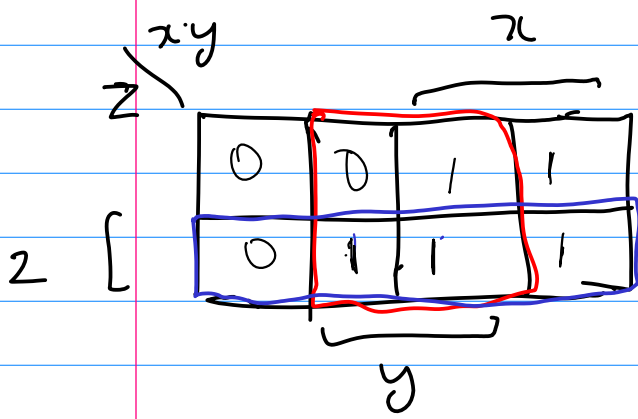

$$RHS = (x + y) \cdot (y + z)$$

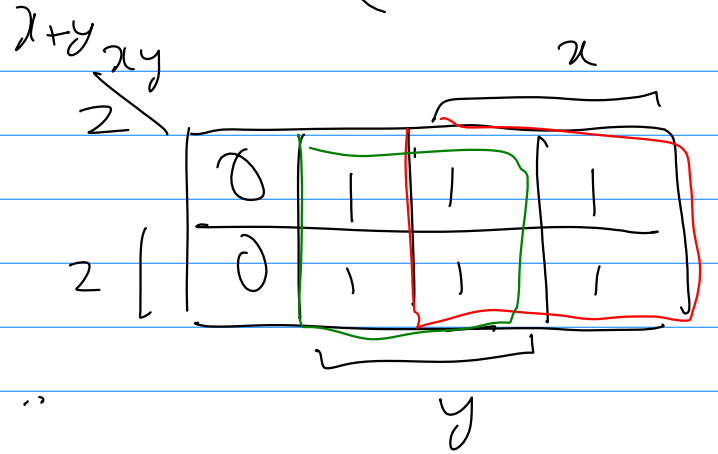

$$y + z = xy$$

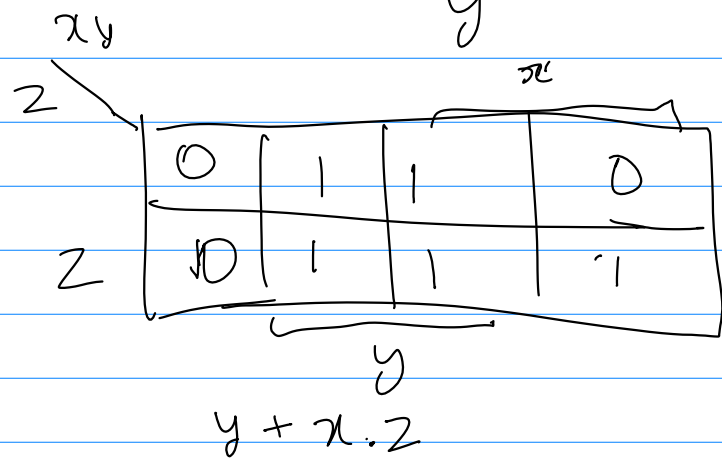
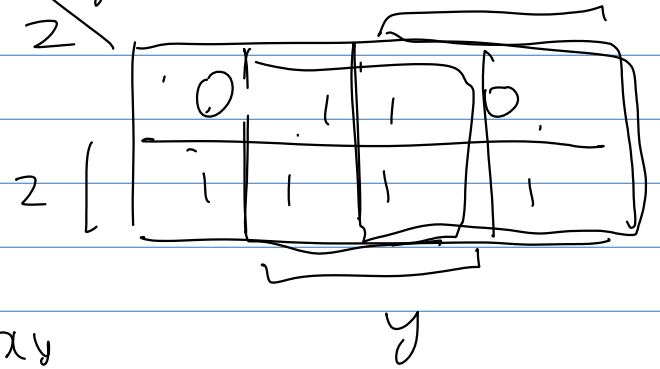

$$x + y \cdot x = x$$

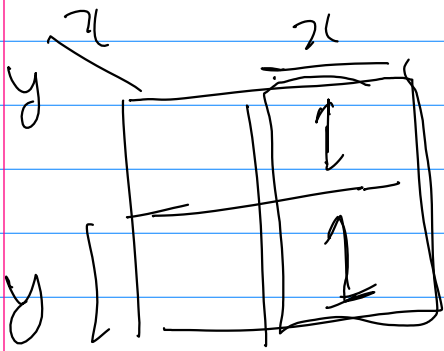

$$x \cdot (y + x) = x$$

~~20~~

$$\text{LHS} = x + y \cdot x = x(1 + y)$$

$$= x \cdot 1$$

$$= x = \text{RHS}$$

LHS =

$$x(y + x) = x \cdot y + x \cdot x$$

$$= x \cdot y + x$$

$$= x(y + 1) = x \cdot 1 = x = \text{RHS}$$

5. Combining: ~~$x \cdot y + \bar{x} \cdot \bar{y}$~~ , $(x + y) \cdot (x + \bar{y}) = x$

$$x \cdot y + x \cdot \bar{y} = x$$

6. DeMorgan's theorem: $\overline{x \cdot y} = \bar{x} + \bar{y}$, $\overline{\bar{x} + \bar{y}} = x \cdot y$.

7. Consensus:

(a) $x + \bar{x} \cdot y = x + y$

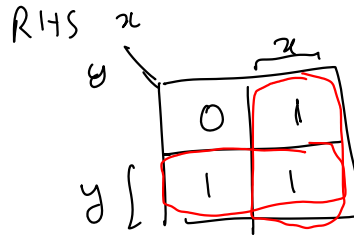
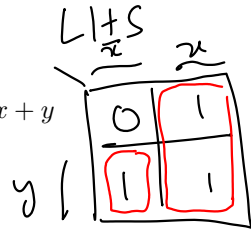

Duals

(b) $x \cdot (\bar{x} + y) = x \cdot y$

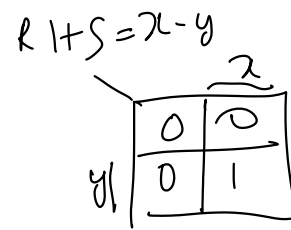
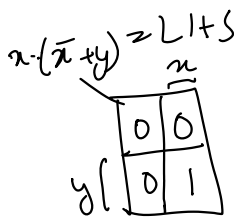
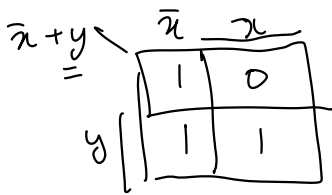

(c) $x \cdot y + y \cdot z + \bar{x} \cdot z = x \cdot y + \bar{x} \cdot z$

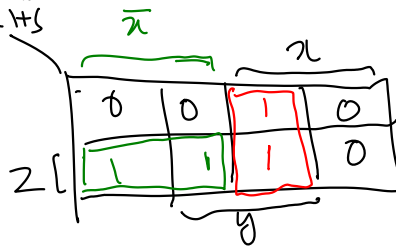
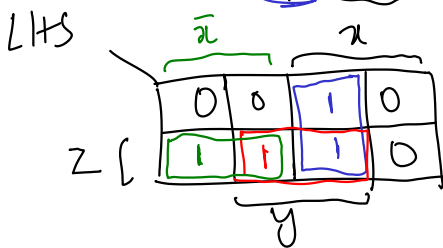

Prove this using k-maps \rightarrow (d) $(x + y) \cdot (y + z) \cdot (\bar{x} + z) = (x + y) \cdot (\bar{x} + z)$

$$(x+y) \cdot (y+z) \cdot (\bar{x}+z) = (x+y) \cdot (\bar{x}+z)$$

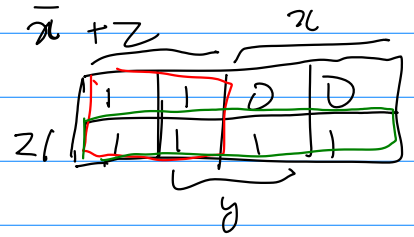
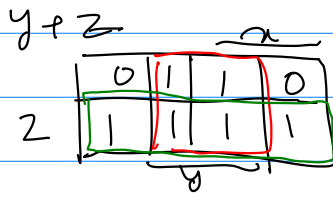
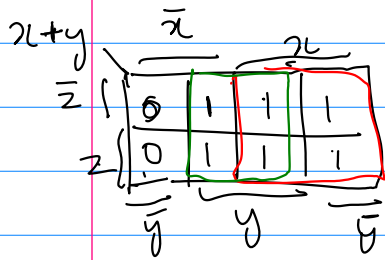

$$\text{LHS} = (x+y)(y+z)(\bar{x}+z)$$

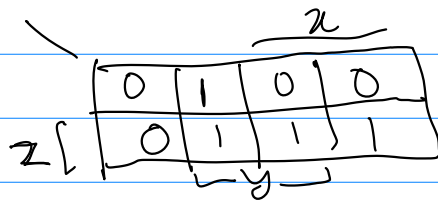

$$\text{RHS} = (x+y)(\bar{x}+z)$$

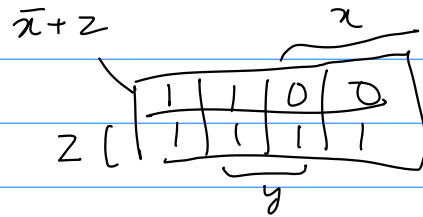
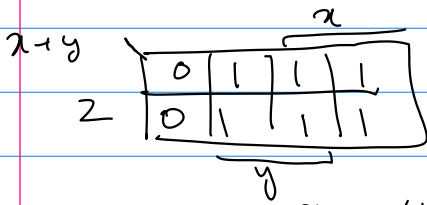

$$\text{RHS} = (x+y)(\bar{x}+z)$$

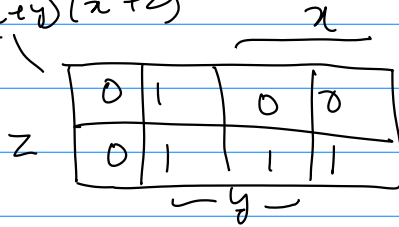

De Morgan's Theorem

$$\overline{x \cdot y} = \overline{x} + \overline{y}$$

$$\overline{x \cdot y \cdot z} = \overline{x} + \overline{y} + \overline{z}$$

$$\overline{\overline{x} + \overline{y} + \overline{z}} = \overline{\overline{x \cdot y \cdot z}}$$

$$LHS = \overline{x \cdot y}$$

$x \cdot y =$

	x	\overline{x}
y	0	0
\overline{y}	0	1

$\overline{x \cdot y}$

	x	\overline{x}
y	1	1
\overline{y}	1	0

$$RHS = \overline{\overline{x} + \overline{y}}$$

	\overline{x}	$\overline{\overline{x}}$
\overline{y}	1	1
y	1	0

De Morgan Theorem

as Bubble pushing

NOT gate

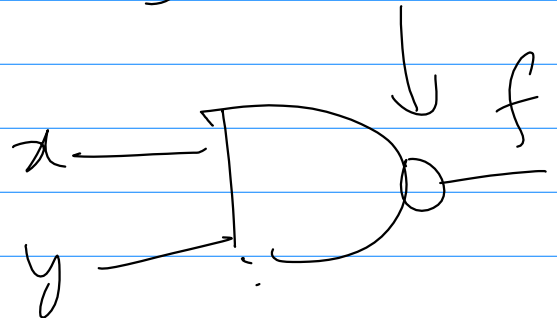
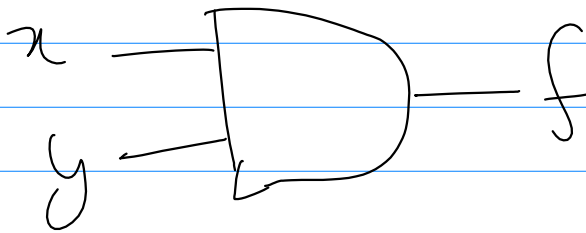

NAND

$$f = \overline{x \cdot y} = \overline{x} + \overline{y}$$

Bubble pushed through
AND gate

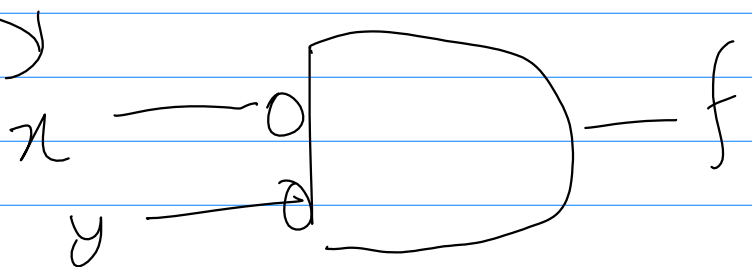
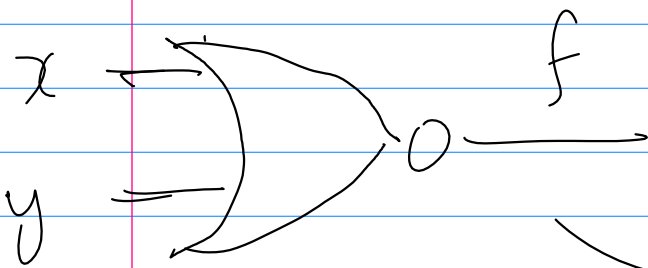
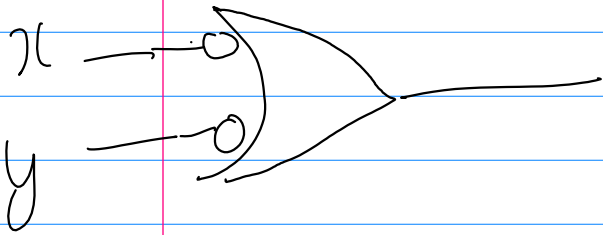

Sum of products form

$$f = x\bar{y} + \bar{x}y$$

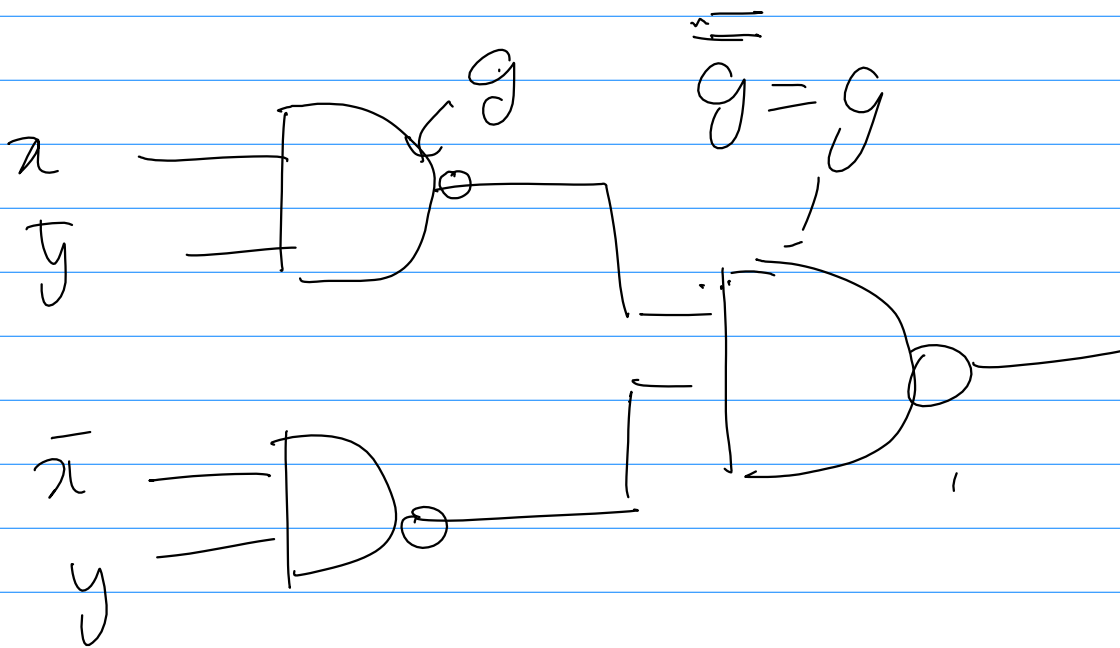
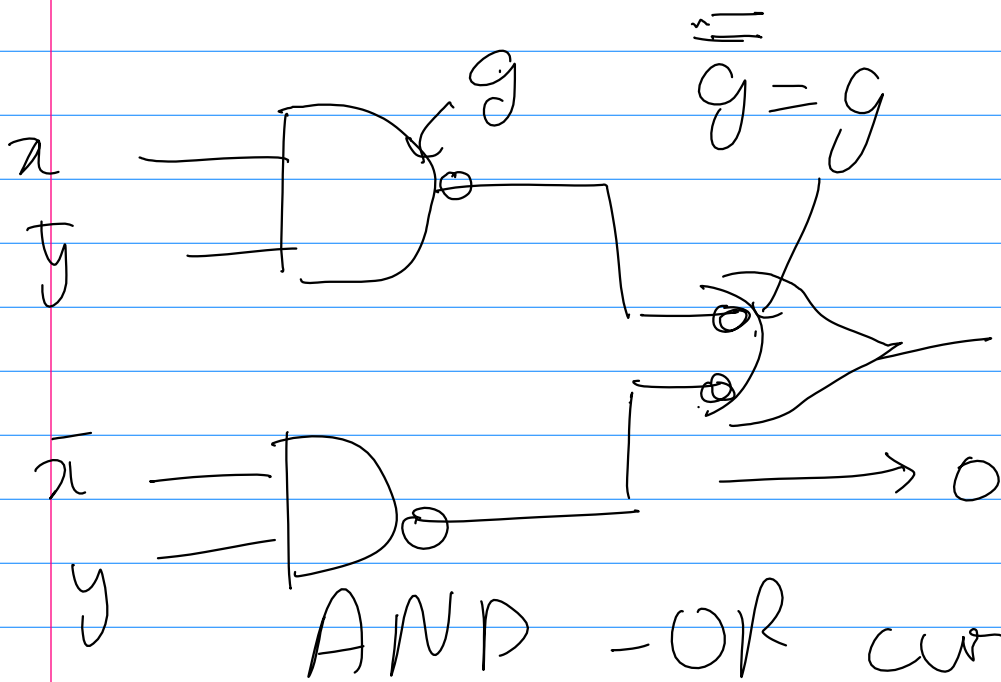

NAND - NAND circuit

$$\text{LHS} = x \cdot y + x \cdot \bar{y}$$

$$= x \cdot (y + \bar{y})$$

$$= x \cdot 1$$

$$= x = \text{RHS}$$

Dual

$$\text{LHS} = (x + y)(x + \bar{y})$$

$$= \underbrace{x \cdot x}_{x} + x \cdot \bar{y} +$$

$$y \cdot x + y \cdot \bar{y}$$

$$= x + x \cdot \bar{y} + y \cdot x$$

$$+ \underbrace{y \cdot \bar{y}}_0$$

$$= x + \underbrace{x \cdot \bar{y} + y \cdot x}_0 + 0$$

$$= x + x(y + \bar{y})$$

$$= x + x \cdot 1$$

$$= x + x$$

$$= x$$

Example 11 (Multiplexer). Multiplexer is a circuit used to select one of the input lines x_1 and x_2 based only select input s . When $s = 0$, x_1 is selected, x_2 is selected otherwise. Find a boolean expression and a circuit for multiplexer

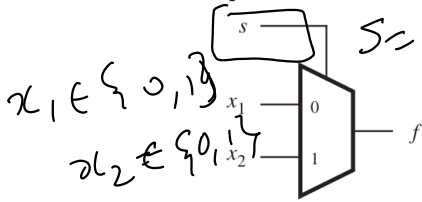

s	$f(s, x_1, x_2)$
0	x_1
1	x_2

s	x_1	x_2	f
0	0	0	0
0	0	1	0
0	1	0	1
0	1	1	1
1	0	0	0
1	0	1	1
1	1	0	0
1	1	1	1

Example 12. Simplify $f = \bar{A}\bar{B}\bar{C} + A\bar{B}\bar{C} + A\bar{B}C$ using boolean algebra

$$f = \underbrace{\bar{A}\bar{B}\bar{C}}_{m_0} + \underbrace{A\bar{B}\bar{C}}_{m_4} + \underbrace{A\bar{B}C}_{m_6}$$

$$= (\bar{A} + A)\bar{B}\bar{C} + A(\bar{B} + B)\bar{C}$$

$$= \bar{B}\bar{C} + A\bar{C}$$

Example 13. Simplify $f = A\bar{A}\bar{C} + \bar{A}\bar{B}C$ using K-maps.

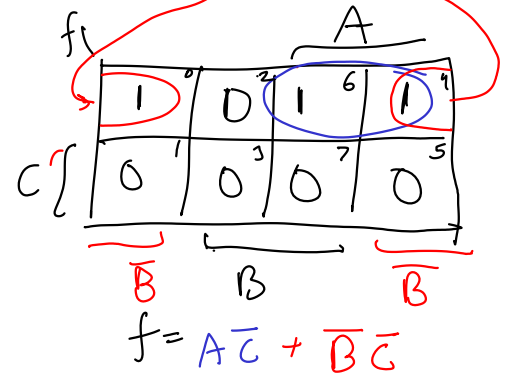

$$\begin{aligned}x + \bar{x} &= 1 \\x \cdot x &= x\end{aligned}$$

$$\begin{aligned}f &= \underbrace{\bar{A}\bar{B}\bar{C}}_{m_0} + \underbrace{A\bar{B}\bar{C}}_{m_4} + \underbrace{AB\bar{C}}_{m_6} \\&= \bar{A}\bar{B}\bar{C} + A\bar{B}\bar{C} + A\bar{B}\bar{C} + AB\bar{C} \\&= \underbrace{(\bar{A} + A)}_1 \bar{B}\bar{C} + A \underbrace{(\bar{B} + B)}_1 \bar{C} \\&= \bar{B}\bar{C} + A\bar{C}\end{aligned}$$

$$\begin{aligned}x + \bar{x} &= 1 \\x \cdot \bar{x} &= 0\end{aligned}$$

S, x_1, x_2

	S	x_1	x_2	f
0	0	0	0	0
1	0	0	1	0
2	0	1	0	1
3	0	1	1	1
4	1	0	0	0
5	1	0	1	0
6	1	1	0	0
7	1	1	1	1

S, x_1

	S	x_1	x_2
0	0	1	0
1	0	1	3
2	1	0	0
3	1	0	1

x_1, x_2

	x_1	x_2
0	0	0
1	0	1
2	1	0
3	1	1

x_1, x_2

	x_1	x_2
0	0	1
1	0	1
2	1	0
3	1	1

	x_1	x_2	S	f
0	0	0	0	0
1	0	1	0	0
2	1	0	0	1
3	1	1	0	1

f

S, x_1

	\bar{S}	S
0	0	0
1	1	0
2	0	1
3	1	1

$f = m_2 + m_3 + m_5 + m_7$

$f = x_1 \cdot \bar{S}$
 $+ x_2 x_1 \leftarrow \text{unnecessary}$
 $+ x_2 \cdot S$

$f = x_1 \cdot \bar{S} + x_2 S$